



**An advanced world of
intelligent gas detection
system management**

Sieger System 57



A world of control technology

- High precision, intelligent control
- Master/voted alarm options
- High packing density
- Flexible I/O configuration
- Relay output options

System 57 - the heart of fire and gas control

For almost half a century, Sieger gas detection systems have provided the safety needed to protect plant and personnel from flammable and toxic gas hazards. Across the globe, they are installed in a wide variety of applications ranging from simple small scale systems to some of the world's largest fully integrated fire and gas detection systems.

To fulfil the unique requirements of each individual application requires a control system with unlimited flexibility. The modular design approach employed by the Sieger System 57 enables you to define, in detail, the unique control and alarm parameters to fulfil your requirement.

System 57 accepts inputs from flammable and toxic gas detectors, a large range of flame, smoke and heat detectors and manual call points. Available outputs include relays, analog signals and industry standard digital protocols. Packaged in either wall mounting cabinets or panel mounting racks, System 57 can be used stand alone or integrated into the heart of a fire and gas system.

Whatever the application, large or small, our sales engineers and customer service representatives are available to discuss your requirements and recommend the control system that's best for you.

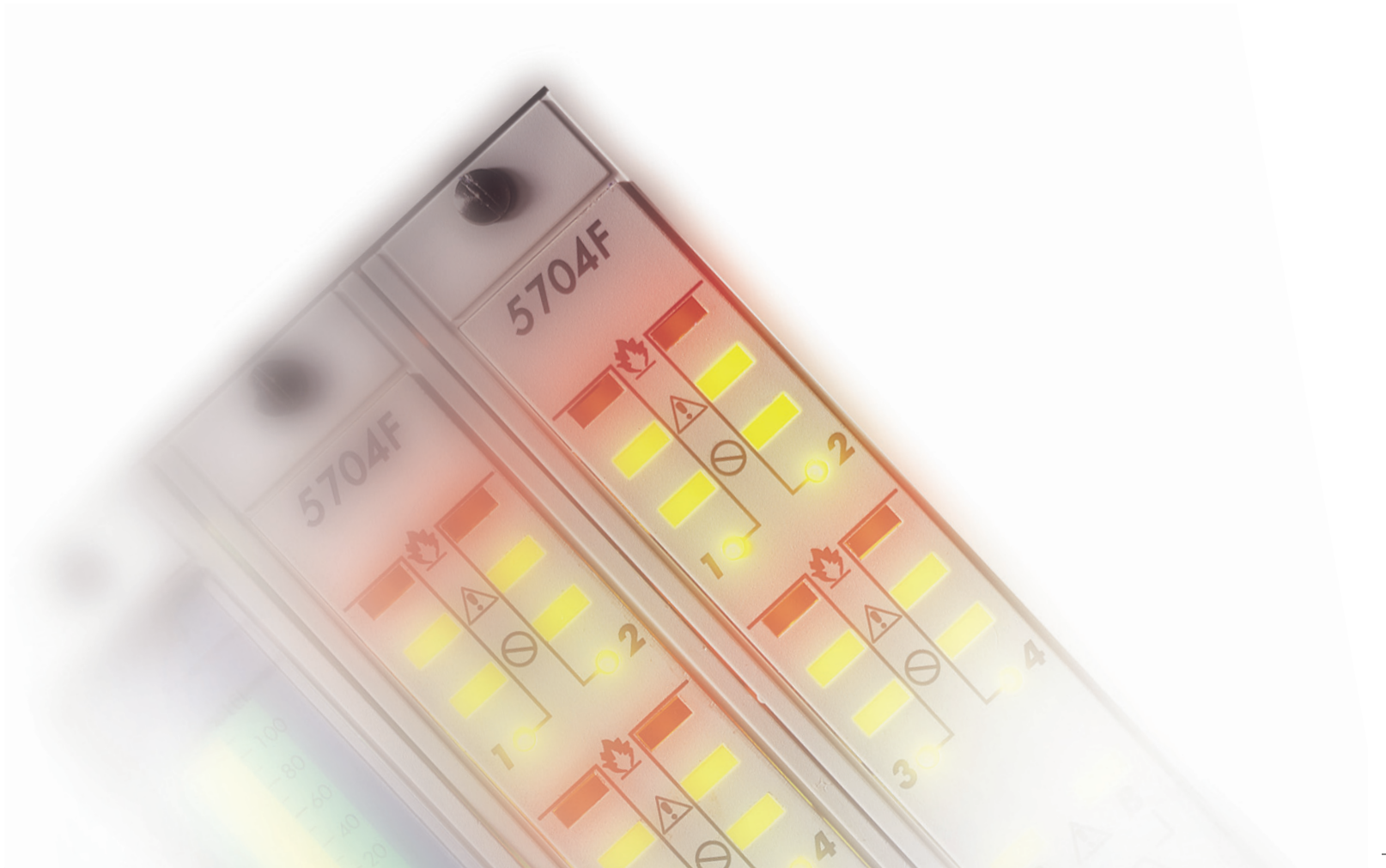

Technical Summary



5704F Fire Card Specification	5704 Fire Card	5704 Fire Status Panel
Audible Sounder	-	60dB at 1 meter
Remote Facilities	accept, reset and silence	-
Supply Voltage	21V to 32Vdc	18V to 32Vdc
Power Consumption	2W	0.75W
Operating Temperature	-5°C to +55°C	
Storage Temperature	-25°C to +55°C	
Operating Humidity	20-90% RH (non condensing)	
Dimensions	3U high x 25mm wide	
Weight	175g	75g
Approvals	EN50270	

Cabinets Racks and Power Supplies Specification	
Cabinets	
Material	Mild Steel
Colour	RAL-7015 - slate grey
Hinge	Left hand side
Lock	Right hand side
Rack Mounting	8 way: half 19" profile. 16 way: 19" universal profile
Pre-formed Gland Entries	8 way: 2 x M25; 2 x PG16; 8 x M20; 6 x PG11 16 way: 3 x M25; 4 x PG16; 16 x M20; 10 x PG11
Environmental Protection	IP54
Mounting Plate	8 way: 120mm high x 220mm wide 16 way: 120 mm high x 440mm wide
Earthing Points	Main Cabinet: M6. Door: M5.
Mounting Bracket Holes	10mm diameter
Weight	8 way: 10.0kg 16 way: 13.5kg
Racks	
Material	Galvanized Steel
Colour (Mounting Brackets)	RAL-7015 - slate grey
Mounting	8 way: half 19" profile. 16 way: 19" universal profile
Earthing Point	M5 stud
Mounting Bracket Holes	6mm diameter
Supply Voltage	18 to 32Vdc
Power Consumption	1.5W
Operating Temperature	-5°C to +55°C
Storage Temperature	-25°C to +55°C
Operating Humidity	0-90%RH (non-condensing)

Cabinets Racks and Power Supplies Specification cont.	
Racks cont.	
Weight	8 way front access 3.9kg 16 way front access 5.8kg 8 way rear access 2.8kg 16 way rear access 4.1kg
Approvals	EN50270
Power Supplies	
Supply Voltage	ac: 85V to 264V; 47Hz to 440Hz dc: 110V to 340V
Inrush Current	typically 30A at 230V input for 50W full load
Output Voltage	24Vdc ± 10%
Power Supply Rating	8-way: 50W upgradeable to 100W 16-way: 50W upgradeable to 200W
Overload Protection	Operates at more than 105% of rating. Recovery automatic.
Overvoltage Protection	Operates at more than 115% of rating
Mounting	8 way: half 19" profile. 16 way: 19" universal profile
Earthing Point	M5 stud
Mounting Bracket Holes	6mm diameter
Operating Temperature	-25°C to +55°C
Operating Humidity	20-90%RH (non-condensing)
Weight	8 way, 50W 0.9kg 16 way, 50W 0.96kg subunit: 815g 50W module 230g
Colour	Front: RAL-7015- slate grey Body: Black anodize
Approvals	EN50270

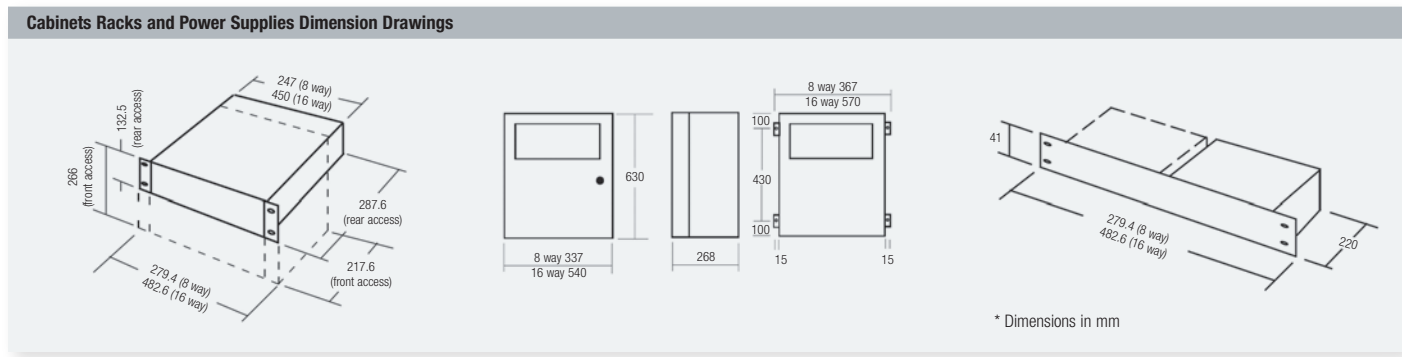

Sieger System 57



1 5701 Gas Control Card

This provides a single channel control function within a 1" wide package.

- Independent single channel operation
- Plug-in input and output options

2 5704 Gas Control Card

This provides four channels of control function within a 1" wide package.

- 4-channel operation
- Choice of output options
- Channel displayed: automatic sequencing, highest reading, combination or manual channel display selection options

3 5704F Fire Control Card

This provides four zones of fire control within a 1" wide package.

- 4 zone fire card
- 2 line monitored outputs
- Up to 15 cards in a 19" rack

4 5704FS Fire Status Panel

Each rack that contains a 5704F fire card has one 5704FS fire status panel fitted. The 5704FS fire status panel provides common display and alarm indication for all of the fire cards in a rack as well as a local audible sounder. It also provides common push buttons for executing specific fire card related functions.

- Common fire control card push button functions
- Common display and alarm indications
- Local audible sounder

5 Master Alarm Update Panel

The master alarm update facility can be enhanced by adding the optional master alarm update panel.

- 1" wide panel
- Audible and visual alarm
- Reset and accept push button
- Provides update facilities without the need for external wiring

6 Power Supply Units

The power supply units are rack mounted to complement the System 57 systems

- 1U high, 19" & 1/2 19" units
- Upgradeable to 200W in 50W blocks
- Auto sensing input voltage: AC or DC
- Regulated DC output
- Over voltage and overload protected

7 Engineering Card

The System 57 engineering card provides full maintenance and set up facilities for each channel card. The front panel has a series of tactile feedback push buttons that allows checks of the alarm levels and performance to be carried out for each channel. A real-time 'on board' clock provides calibration history and calibration overdue reminder functions.

- Security protected
- User friendly operation
- Calibration facility
- Command accept/abort facility
- Channel card set up capability

Sieger System 57



Optional analog output module



1

Analog input board

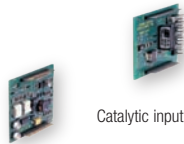

Catalytic input board



4



5

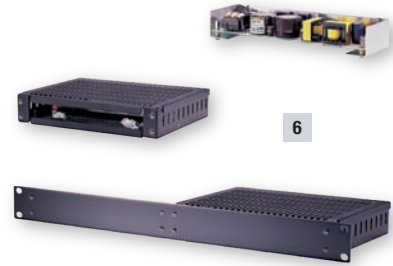

6



2



3



7

10



9



9



10



Blank panel

8

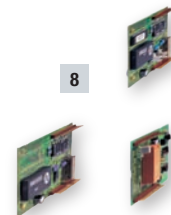

Sieger System 57



8 Engineering Card Modules

A number of plug-in options for the extended system capabilities:

8a Serial Communications Module

The serial communications module provides a gateway between the System 57 rack and a remote device (DCS, PLC or SCADA package) to allow the continuous monitoring of each channel's operation and condition as well as allowing remote configuration of the system operation.

- Industry standard MODBUS RTU protocol
- RS485/422/232 standard
- Bi-directional
- Electrically isolated communications bus
- SCADA graphics package available

8b RS232 Printer Driver Module

The printer driver module provides a serial output in the event of a gas alarm, fault or user intervention.

- RS232 ASCII event data
- Selectable print criteria
- Time and date stamping
- Electrically isolated communications bus

8c Master Alarm Update Module

The alarm update module provides a common alarm indication with new alarm event update.

- 2 Outputs: 1 relay, 1 Darlington
- Selectable operation: pulsed, continuous
- Alarm accept input
- Common alarm reset input
- Complies with ISA 'M', DIN 19 235
- Optional master alarm update panel

9 Interface Cards

There are 9 versions of interface card available (5 for 5701 Gas, 2 for 5704 Gas and 2 for 5704 Fire Control Cards). The interface cards provide the link between the various fire or gas detectors and the control cards.

- Sensor interface
- Flexible relay options
- Individual control card power option
- High integrity operation option
- Accepts $\leq 2.5\text{mm}/14$ gauge cable

10 Rack Assemblies

System 57 racking units provide mounting options for the system 57 control cards and interface cards. The racks are available complete with a DC input card and an engineering card.

- 3U high format
- Front and rear wiring options
- Half and full 19" versions
- Up to 64 channels of gas detection or 60 channels of fire detection in a single rack, or a combination of both.

Cabinet Assemblies

The System 57 cabinets provide a convenient and compact mounting of the rack assemblies and PSUs

- Wall mounting half and full 19" versions
- IP54/Nema 12 cabinet protection rating
- Preformed knock-out gland entries
- Accessory mounting plate

DC Input Card

The DC input card is connected directly to the engineering card and provides the connection point for power supplied to the whole rack.

The field wiring from the engineering card modules is also on this card.

- Common power supply wiring point
- Reverse polarity and short circuit protection
- Multi-supply input capability

Technical Summary



Interface Card Selection Table	5701 Gas Interface Card Type					5704 Gas Interface Card Type		5704F Fire Interface Card Type	
	Field Interface	Double SPCO	Triple SPCO	Triple DPCO	High Integrity	Quad Relay	Relay Interface	Hex Relay	Relay Interface
Sensor Connection	•	•	•	•	•	•	•	•	•
No relays	•								
3 SPCO Relays		•							
5 SPCO Relays			•						
8 Changeover Relays				•					
8 Changeover Relays*					•				
4 SPCO Relays**						•			
12 SPCO and 4 SPST Relays**							•		•
6 SPCO Relays**								•	
24V in	•	•	•	•	•	•	•	•	•
24V out	•	•	•	•	•				
Analog ***	•	•	•	•	•	•	•		
Remote Inhibit	•	•	•	•	•	•	•		
Remote Reset	•	•	•	•	•	•	•		
Remote Accept, Reset, Silence								•	•
2 x line monitored outputs								•	•

* 8 relays (7 fully configurable, 1 for fault alarm). Configurable master alarm functions or a mixture of master and individual alarms. The relay states are monitored by the control card to ensure correct operation of the relays. ** Fully configurable for individual or master alarms and relay operation. *** With optional analog output module fitted to control card.

5704F Indications		Indication	
Function	Colour	Continuous	Flashing
5704 Fire Card			
Fire	Red	Fire condition on zone (accepted)	New fire condition (not accepted)
Fault	Yellow	Fault condition on zone (accepted)	New fault condition (not accepted)
Inhibit	Yellow	Zone inhibited	-
Output channel	Yellow	Output channel in fault condition (accepted)	New output fault condition (not accepted)
Selected zone	Yellow	Active when zone has been accepted	-
Card fault	Yellow	Card fault (accepted)	Card fault (not accepted)
Power	Green	Healthy	-
5704 Fire Status Panel			
Master fire	Red	Fire condition on at least one zone (accepted)	New fire condition (not accepted)
Master fault	Yellow	Fault condition on at least one zone (accepted)	New fault condition (not accepted)
Master inhibit	Yellow	At least one zone inhibited	-
Master silence	Yellow	At least one output silenced	-
Master walk test	Yellow	At least one zone in walk test mode	-
Earth fault	Yellow	Earth fault (accepted)	New earth fault (not accepted)
Power	Green	Healthy	-
Audible Mode		Indication	
Continuous		New fire condition (not accepted)	
1s ON, 1s OFF		New fault condition (not accepted)	
1s ON every 10s		Fire signal on at least one zone (accepted)	
1s ON every 30s		Fault signal on at least one zone (accepted)	

Technical Summary



5701/4 Gas Card Specification	5701 Control Card	5704 Control Card
Control Card	5701 Control Card	5704 Control Card
Back lit LCD	Bar graph+peak reading, digital, alphanumeric	Bar graph+peak reading, digital, alphanumeric
Front Panel Facilities	Red LED: A1, A2, A3 Yellow LED: fault, inhibit Green LED: power Push button: alarm reset/card select	CH1-4 LEDs: A1, A2, A3, fault, inhibit per channel Attn LED: card fault, update alarm, alarm test Green LED: power Push button: alarm reset/card select
Remote Facilities	Inhibit and remote alarm reset	Inhibit and remote alarm reset
Supply Voltage	18V to 32Vdc	18V to 32Vdc
Power Consumption	Catalytic: 3.75W 4-20mA: 3.25W	Catalytic: 12.8W 4-20mA: 8.4W
Display/Alarm Point	Linearity: 1% fsd Repeatability: 1% fsd	Linearity: 2% fsd Repeatability: 2% fsd
Electronic Drift	Less than 2% / 6 months	Less than 3% / 6 months
Operating Temperature	-5°C to +55°C	-5°C to +55°C
Storage Temperature	-25°C to +55°C	-25°C to +55°C
Operating Humidity	20-90% RH (non condensing)	20-90% RH (non condensing)
Dimensions	3U high x 25mm wide	3U high x 25mm wide
Weight	165g	165g
Approvals	EN50270	EN50270
Catalytic Bridge Input		
Drive Method	Constant current	Constant current
Current Range	70mA to 283mA	90mA to 315mA
Full Scale Range	15mV to 600mV	15mV to 300mV
Maximum Line Resistance	40 ohms at 250mA (including sensor)	40 ohms at 200mA (including sensor)
4-20mA Input		
Loop Powered Voltage	23V ± 5% isolated	24V ± 5% isolated
Sensor Configuration	current sink or source	current source
Signal Measurement Range	0 to 25mA	0 to 25mA
Maximum Loop Resistance	500 ohms (including sensor)	500 ohms (including sensor)
Analog Output Option		
Measurement Signal Range	0 to 20mA or 4 to 20mA	0 to 20mA or 4 to 20mA
Linearity From Input	Better than 2% fsd	Better than 2% fsd
Repeatability From Input	Better than 1% fsd	Better than 1% fsd
Configuration	Isolated current sink or source (with external supply)	Isolated per card for current sink or source (with external supply)

Interface Card Specification	5701 Interface Relay Cards	5704 Interface Relay Cards	5704F Interface Relay Cards
Relay Contacts	5A at 250Vac/32Vdc (non-inductive)		
Relay Operation	selectable- latching/non-latching, normally energized/ de-energized		
Power Consumption	Field Interface card 0.0W	Quad Relay Interface 1.7W	Hex Relay Interface 2W
	Double SPCO card 0.8W	Relay Interface Assembly 6.5W	Relay Interface Assembly 6.5W
	Triple SPCO card 1.0W		
	Triple DPCO card 1.6W		
	High Integrity card 1.7W		
Terminals	accepts up to 2.5mm ² (14AWG) cable		
Operating Temperature	-5°C to +55°C		
Storage Temperature	-25°C to +55°C		
Operating Humidity	20-99% RH (non condensing)		
Weight	Field Interface card 95g	Quad Relay Interface 230g	Hex Relay Interface 250g
	Double SPCO card 155g	Relay Interface Assembly 500g	Relay Interface Assembly 500g
	Triple SPCO card 205g		
	Triple DPCO card 245g		
	High Integrity card 255g		
Approvals	EN50270		

Sieger System 57



Control Cards

The System 57 offers unrivalled flexibility with both Fire and Gas control cards available in the same rack.

Gas Control Cards

The System 57 gas control cards provide display and alarm facilities for the full range of Sieger gas detectors.

Their concise, back lit, multi-part LCD displays the gas reading and status in both analog bar graph and digital numeric forms. In addition, there is an alpha numeric message section to give sensor (and engineering function) status.

There is a choice of either the single channel 5701 or the four channel 5704 gas control cards. Each card has two input options; one is for catalytic bridge type while the other is for 4 to 20mA sensors or transmitters.

- 3 levels of alarm
- Options of individual, zoned, voted, master, time delayed, update and rate of rise alarm facilities
- Clear 4 part LCD display
- Peak reading facility
- Sensor performance monitoring

Fire Control Cards

The 5704F Fire control cards provide display and alarm facilities for a wide variety of fire detection products and provides up to four fire zone inputs compatible with most flame, smoke and heat detectors and manual call points. The status of each fire zone is individually displayed by high intensity LEDs.

In addition, each card has two line monitored alarm output circuits.

Both Fire and Gas control cards can be freely mixed in a rack.

- High intensity LED indications
- Up to 60 fire zones per 19" rack
- Configurable for use with a wide range of fire detection products



Single Channel Gas Control Card



Four Channel Gas Control Card



Four Zone Fire Card



Fire Status Panel



Engineering Card

Oil and Gas

- Petrochemical
- Onshore
- Offshore

Industrial

- Chemical
- Semi-conductor
- Water treatment
- Food

Commercial

- Building services
- Car parks
- Boiler houses

Engineering Card Modules	
Serial Communication Modules	
Power Consumption	RS232: 0.75W RS422/485 :1.5W
Maximum Cable Length	RS232: 15m (49ft) RS422/485 :1200m (3900ft)
Protection	Thermal shutdown
Isolation	50V relative to system 0V
Operating Temperature	-5°C to +55°C
Storage Temperature	-25°C to +55°C
Operating Humidity	0-90%RH (non-condensing)
Weight	30g
Approvals	EN50270
Serial Communication	
Format	Asynchronous Serial Data
Data Bits	8
Stop Bits	1 or 2
Parity	odd, even or none
Data Rate	19200 (not RS232), 9600, 4800 or 2400 baud
MODBUS Protocol	
Mode	RTU
MODBUS Functions	02, 03, 04, 06 & 16
RS232 Interface Module	
Inputs/Outputs	Two data (RXD, TXD), two handshake (DTR, DSR)
Input Threshold	Positive: 3V maximum, . Negative: 0.6V minimum
Output Voltage	±5V minimum
Input Hysteresis	500mV typical
Common Mode Voltage	-15V minimum to +15V maximum

Find out more

www.honeywellanalytics.com

Customer business centre

Europe and the rest of the world

Honeywell Analytics AG
 Wilstrasse 11-U11
 CH-8610 Uster
 Switzerland
 Tel: +41 (0)44 943 4300
 Fax: +41 (0)44 943 4398
sales@zelana.co.uk

Customer business center

Americas

Honeywell Analytics Distribution, Inc.
 400 Sawgrass Corporate Pkwy
 Suite 100
 Sunrise, FL 33325
 USA
 Tel: +1 954 514 2700
 Toll free: +1 800 538 0363
 Fax: +1 954 514 2784
sales@zelana.com

www.honeywell.com

Please Note:

While every effort has been made to ensure accuracy in this publication, no responsibility can be accepted for errors or omissions. Data may change, as well as legislation, and you are strongly advised to obtain copies of the most recently issued regulations, standards, and guidelines. This publication is not intended to form the basis of a contract.
 © 2006 Honeywell Analytics

H_System57_BR0102_V1
 08/06

© 2006 Honeywell Analytics

Engineering Card Modules cont.	
RS232 Printer Driver	
Power Consumption	0.75W max
Operating Temperature	-5°C to +55°C
Storage Temperature	-25°C to +55°C
Operating Humidity	0-90%RH (non-condensing)
Weight	30g
Approvals	EN50270
Serial Communication	
Format	Asynchronous Serial Data, ASCII text or EPSON emulation
Data Bits	8
Stop Bits	1
Parity	None
Data Rate	9600 baud
Printer Compatibility	
Configuration Options	Carriage return, line feed, date format
RS 232 Interface	
Cable Type	Screened multi-core wire recommended
Inputs/Outputs Specification	
Maximum Cable Length	15m (49ft)
Maximum Data Rate	9600 bits per second
Input Hysteresis	500mV typical
Output Voltage	±5V minimum
Input Threshold	Positive: 3V maximum, . Negative: 0.6V minimum
Common Mode Voltage	-15V minimum to +15V maximum
Protection	Thermal shutdown
Isolation	50V relative to system 0V
Master Alarm Update	
Power Consumption	Update Module: 0.25W max. Update Panel 0.2W max
Weight	Update Module: 25g. Update Panel 35g
Operating Temperature	-5°C to +55°C
Storage Temperature	-25°C to +55°C
Operating Humidity	0-90%RH (non-condensing)
Approvals	EN50270
Relay Output Contact Type	Single pole link selectable for normally open or closed operation
Relay Contact Rating	2A at 40Vdc (non-inductive)
Isolation	50V relative to system 0V
Remote Inputs	Update alarm accept and master reset
Input Threshold	2V
Maximum Input Current	5mA
Master Alarm Update Module	
Modes	Steady or Pulsed
Pulse On/Off Time	Adjustable (0 to 25.5 in 0.1 sec intervals)
Transistor Output	
Maximum Input Voltage	40Vdc
Maximum Input Current	100mA
Saturation Voltage (VCE)	3V (maximum)
Protection	Thermal over-current shutdown
Master Alarm Update Panel	
Dimensions	3U high x 25mm wide
Switch Inputs	Update alarm accept and master reset
Contact Type	Push-button momentary action
Visual Output Type	Piezo electric buzzer
Nominal Frequency	2kHz
Sound Level	85dB at 100mm