

VIKING® HEAVY DUTY PUMPS

SERIES 125 AND 4125 STANDARD CONSTRUCTION

Section	141
Page	141.1
Issue	D

FEATURES

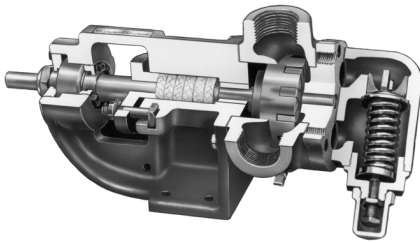

SERIES 125 Pumps
Cutaway View — (Packed Type)
8-15-30 GPM Sizes
(2-3-7 m³/hr)



SERIES 4125
Cutaway View— (Mechanical Seal Type)
50-75-100-135 GPM Sizes
(11-17-23-31 m³/hr)

Note: 50 and 75 GPM sizes have seal located in stuffing box area.

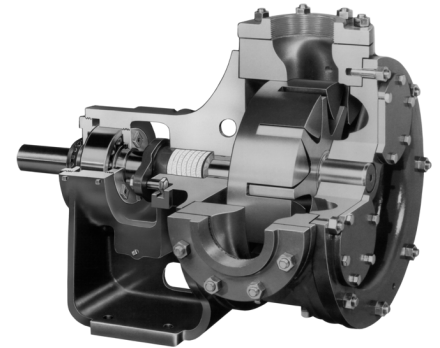

SERIES 125 Pumps
Cutaway View— (Packed Type)
140-200-300-420-500 GPM Sizes
(32-45-68-95-114 m³/hr)

Note: 500 GPM ("QS" size) has opposite ports as standard.

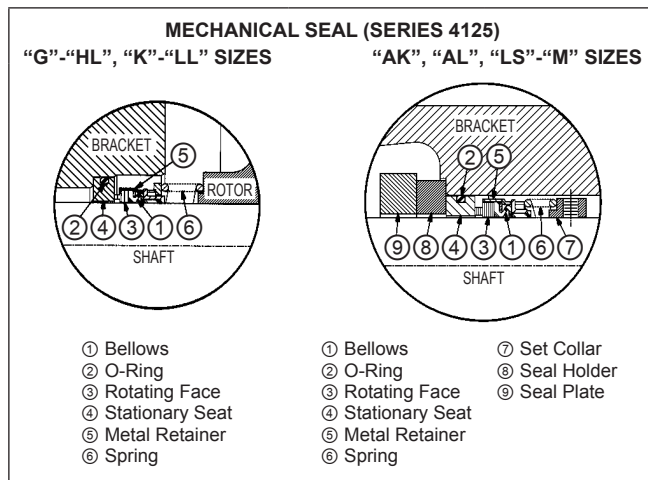

① Pressure Range	200 PSI (14 BAR) for 100 SSU (21 cSt) and above
	100 PSI (7 BAR) for below 100 SSU (21 cSt)
① Temperature Range	-60°F. to +650°F. (-51°C. to +343°C.)
① Viscosity Range	28 SSU to 2,000,000 SSU (0.1 cP to 440,000 cSt)

GPM 8-15-30-50-75-100-135-140-200-300-420-500
(m³/hr 2-3-7-11-17-23-31-32-45-68-95-114)
② (Nominal Rating)

It is the unique and unusually simple construction that has made our rotary pumps so adaptable to so many diversified installations. They possess excellent vacuum developing characteristics and operate equally well in either direction. Because of the cushioned action in providing a continuous and steady stream of liquid without foaming or churning, it is adaptable to an unlimited number of industrial applications.

The rugged construction of these heavy-duty pumps assures long life and peak, trouble-free operation on normal-duty installation and outstanding performance when handling liquids at greater pressures.

These heavy-duty pumps are furnished as standard with packed-type or mechanical seal construction for shaft protection and prevention of leakage. Packed pumps provide extra-deep stuffing box. The rotary-type mechanical seal works with, rather than against, pressure. It is self-adjusting and seals without leakage. Because of its method of sealing it prevents scoring of the pump drive shaft.

The Series 4125 mechanical seal pumps can handle liquids with viscosities up to 15,000 SSU. Special seals for higher viscosities are available; consult factory.

① Values shown represent minimums or maximums. Some special construction or consideration may be required before a cataloged pump can be applied to an application involving maximum pressure or minimum or maximum temperature and/or viscosity. Certain models have restrictions in pressure and/or viscosities. See specifications, page 141.2, and performance curves.

② Nominal capacities based on handling thin liquids at low pressures.

Metric conversions are based on US measurements and rounded to the nearest whole number.

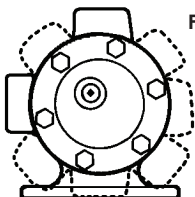

REVOLVABLE PUMP CASING
(Standard Equipment)

All Series 125 and 4125 pumps are equipped with pump casings that can be turned to eight positions except the "LQ", "LL", and "QS" sizes. These can be turned in all positions except for a port in the 6 o'clock position. Relief valve must point to suction port in all cases.

FEATURES

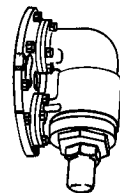

OVERPRESSURE RELIEF VALVE
(Standard Equipment)

Valve permits bypassing of liquids and prevents excessive pressures in the discharge line. If reversing pump, remove valve and turn end for end. Relief valve must point to suction port in all cases. All valves set at 50 lbs. unless otherwise requested. If overpressure relief valve is not used, pumping system should include some form of overpressure protection, e.g., relief valve in discharge line, torque limiting devices, rupture discs, etc.

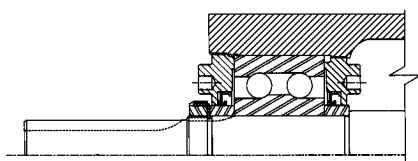

POSITIVE-LOCK THRUST CONTROL

Series 125 and 4125 pumps are manufactured with positive-lock thrust control for accurate axial positioning of rotor and shaft. Illustration shows bearing and double end cap arrangement.

Section	141
Page	141.2
Issue	E

VIKING® HEAVY DUTY PUMPS

SERIES 125 AND 4125

UNMOUNTED PUMPS

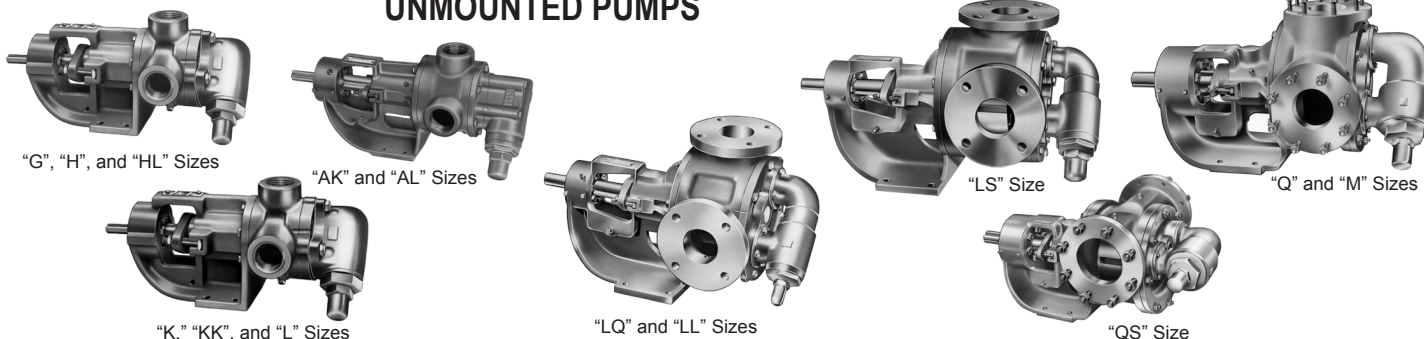

This series of heavy-duty pumps is available either unmounted or mounted as shown on following pages. Available with packed stuffing box or Buna-N mechanical seal with carbon rotating and Ni-Resist stationary faces. The integral thrust bearing is designed to handle heavy-duty pumping jobs without problems of end play and distortion. For increased versatility of installation and complete selection of ports, many of the pump casings are designed so they can be rotated on the bracket to any 45° or 90° angle from that shown in the illustrations. See

revolvable casing feature on Page 141.1. Overpressure relief valve on head is standard for this series. To permit use of this type pump in a greater range of applications, some sizes are available with jacketed head plate. For heavy-duty pumps with jacketed bracket and head, see Catalog Section 142.

Dimensions for Unmounted Pumps—See Page 141.8.

Performance Data for Unmounted Pumps—See Pages 141.15 through 141.42.

CONSTRUCTION — SERIES 125 AND ① 4125 (“G” THROUGH “M” SIZES)

Pump Construction	Casing	Head	Bracket	Rotor	Idler	Rotor Shaft And Idler Pin	Bushings				Internal Pressure Relief Valve
							Packed		Mechanical Seal		
							Idler	Bracket	Idler	Bracket	
Standard Construction	Iron	Iron	Iron	⑦ Iron	Iron	Steel	Bronze	Bronze	Carbon Graphite	⑩ Bronze	Iron
⑪ Steel Fitted	Iron	Iron	Iron	Steel	② Iron	Steel	Bronze	Bronze	Carbon Graphite	⑩ Bronze	Iron
⑨ Bronze Fitted	Iron	Iron	Iron	⑨ Bronze	Bronze	Steel	Bronze	Bronze	Carbon Graphite	⑩ Bronze	Iron

SPECIFICATIONS — SERIES 125 AND ① 4125 UNMOUNTED PUMPS

Packed	Model Numbers	Port Size	⑥ Nominal Pump Rating		Maximum Hydrostatic Pressure	Steel Fitted Construction Recommended Above This Viscosity	⑧ Maximum Recommended Discharge Pressure When Handling 100 SSU Liquid At Nominal Rated Speeds	⑤ Maximum Recommended Temperature for Cataloged Pump °F. (°C.)		Approximate Shipping Weight With Valve	
			GPM (m³/hr)	RPM				Packed	Mech. Seal		
	G125	G4125	1	8 (2)	1800	400 (28)	⑨ 7,500 (1,650)	200	300 (149)	225 (107)	22 (10)
	H125	H4125	1½	15 (3)	1800	400 (28)	25,000 (5,500)	200	300 (149)	225 (107)	38 (17)
	HL125	HL4125	1½	30 (7)	1800	400 (28)	7,500 (1,650)	200	300 (149)	225 (107)	40 (18)
	AK125	AK4125	2	50 (11)	1200	400 (28)	⑩ 25,000 (5,500)	150	300 (149)	225 (107)	78 (35)
	AL125	AL4125	2	75 (17)	1200	400 (28)	⑩ 25,000 (5,500)	150	300 (149)	225 (107)	81 (37)
	K125	K4125	2	75 (17)	780	400 (28)	25,000 (5,500)	200	300 (149)	225 (107)	105 (48)
	KK125	KK4125	2	100 (23)	780	400 (28)	25,000 (5,500)	200	300 (149)	225 (107)	110 (50)
	L125	L4125	2	135 (31)	640	400 (28)	25,000 (5,500)	200	300 (149)	225 (107)	155 (70)
	LQ125	LQ4125	④ 2½	135 (31)	640	400 (28)	25,000 (5,500)	200	300 (149)	225 (107)	175 (79)
	LL125	LL4125	④ 3	140 (32)	520	400 (28)	2,500 (550)	200	300 (149)	225 (107)	185 (84)
	LS125	LS4125	④ 3	200 (45)	640	400 (28)	75,000 (16,500)	150	300 (149)	225 (107)	190 (86)
	Q125	Q4125	④ 4	300 (68)	520	400 (28)	7,500 (1,650)	150	300 (149)	225 (107)	440 (200)
	QS125	QS4125	④ 6	500 (114)	520	400 (28)	75,000 (16,500)	150	300 (149)	225 (107)	540 (245)
	M125	M4125	④ 4	420 (95)	420	400 (28)	25,000 (5,500)	150	300 (149)	225 (107)	600 (272)

① Buna-N elastomer used in mechanical seal of Series 4125 pumps. Viton®, Neoprene, and PTFE mechanical seals also available.

② “G”, “Q”, and “QS” sizes have steel idler.

③ For mechanical seal pumps on applications with viscosities above 15,000 SSU (3,300 cSt), provide details for recommendation.

④ Ports are suitable for use with 125# ANSI cast iron or 150# ANSI steel companion flanges or flanged fittings. All others tapered for standard pipe.

⑤ Standard seal can be used from -20°F. to +225°F. With special construction, temperatures from -60°F. to +650°F. can be handled with this series pumps.

⑥ Nominal rating based on handling thin liquids.

⑦ “AK”, “AL”, “KK”, “LS”, and “QS” sizes have ductile iron rotor.

⑧ For maximum recommended discharge pressures when handling other viscosities and/or other speeds, see performance curves. Performance curves also show preferred constructions. If suction pressure exceeds 50 PSIG (3 BAR), consult factory.

⑨ Check factory before using bronze rotors at viscosities normally requiring steel-fitted construction. “G”, “AK”, “AL”, “LS”, and “QS” sizes not available in bronze-fitted construction.

⑩ “AK”, “AL”, “LS”, “Q”, “QS”, and “M” 4125 models furnished with carbon graphite bracket bushings and mechanical seal is mounted in stuffing box. Mechanical seal is mounted behind rotor in “G”, “H”, “HL”, “K”, “KK”, “L”, “LQ”, and “LL” pumps.

⑪ “AK” and “AL” sizes not available in steel-fitted construction.

Viton® — Registered trademark of DuPont Performance Elastomers.

Metric conversions are based on US measurements and rounded to the nearest whole number.

VIKING® HEAVY DUTY PUMPS

SERIES 125 AND 4125

Section	141
Page	141.3
Issue	D

VIKING HELICAL GEAR REDUCTION UNITS (“R” DRIVE)

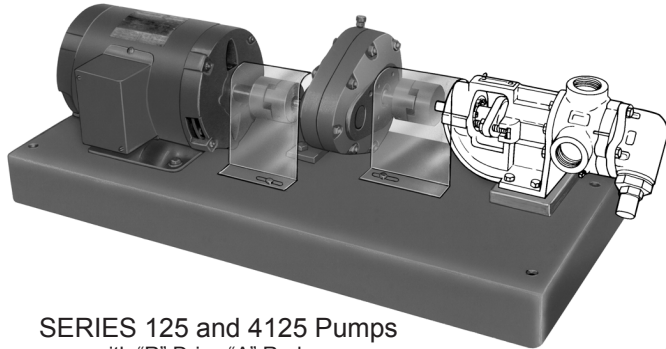

SERIES 125 and 4125 Pumps
with “R” Drive “A” Reducer

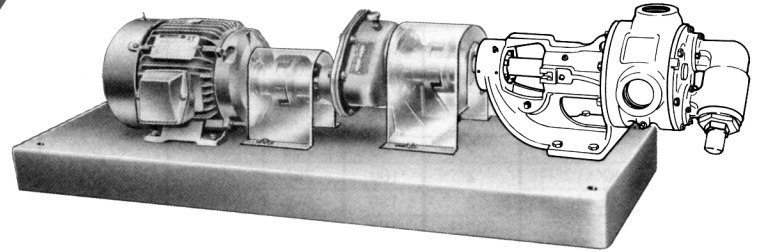

SERIES 125 and 4125 Pumps
with “R” Drive “B” Reducer

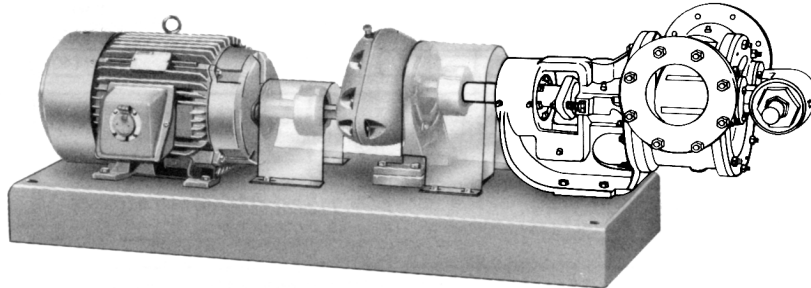

SERIES 125 and 4125 Pumps
“QS” Size with “R” Drive “C” Reducer

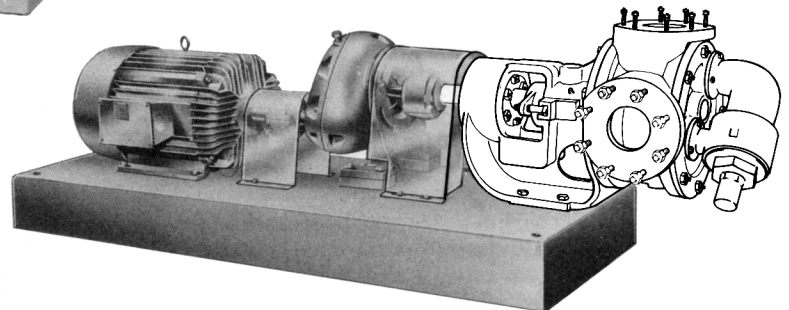

SERIES 125 and 4125 Pumps
with “R” Drive “C” Reducer

Heavy-duty pump Series 125 and 4125 are available with helical gear reducers that have been specifically developed for efficient operation with heavy-duty pumps. These rugged, compact, exceptionally quiet gear reducers come in three sizes: the “small” A size, “medium” B size, and “large” C size and are all bracket mounted requiring flexible couplings for both input and output shafts.

The “A” size reducer, available with four gear ratios (2.24, 2.76, 3.43, and 4.17 to 1), is ideally suited for use with the “G”, “H”, “HL”, “AK” and “AL” size pumps. With the “A” size reducer and 1200 or 1800 RPM motors, the “G”, “H”, “HL”, “AK”, and “AL” size pumps can be used to cover a capacity range to 51 GPM.

The medium size “B” helical gear reducer is available

with eight gear ratios from 1.87 to 1 to 7.65 to 1. This size normally is used with pump sizes “AK” through “LS”. With the “B” reducer, “AK” through “LS” pumps driven by 1200 or 1800 RPM motors can be used to cover a capacity range to 213 GPM.

The large “C” size reducer also is available with seven gear ratios from 2.21 to 1 to 7.65 to 1. It is normally used with the “KK” through “M” size pumps. With the “C” reducer, “KK” through “M” size pumps driven by 1200 or 1800 RPM motors can cover a capacity range to 500 GPM.

Dimensions for “R” Drive Units— See Pages 141.9 and 141.10.

Performance Data for “R” Drive Units—See Pages 141.15 through 141.42.

Section	141
Page	141.4
Issue	E

VIKING® HEAVY DUTY PUMPS

SERIES 125 AND 4125

VIKING HELICAL GEAR REDUCER UNITS (“R” DRIVE)

SPECIFICATIONS — “R” DRIVE UNITS

Model Numbers		Port Size	⑤ Nominal Pump Rating		Maximum Hydro-Static Pressure	Steel-Fitted Construction Recommended Above This Viscosity	③ Maximum Recommended Discharge Pressure When Handling 100 SSU Liquid At Nominal Rated Speeds	⑥ Maximum Recommended Temperature For Cataloged Pump °F. (°C.)		Approximate Shipping Weight With Valve (Less Power) Pounds (KG)		
Packed	① Mech. Seal	Inches	GPM (m³/hr)	RPM	PSIG (BAR)	SSU (cSt)	PSIG	Packed	Mech. Seal	“A” Reducer	“B” Reducer	“C” Reducer
G125R	G4125R	1	8 (2)	1800	400 (28)	7,500 (1,650)	200	300 (149)	225 (107)	109 (49)
H125R	H4125R	1½	15 (3)	1800	400 (28)	25,000 (5,500)	200	300 (149)	225 (107)	125 (57)
HL125R	HL4125R	1½	30 (7)	1800	400 (28)	7,500 (1,650)	200	300 (149)	225 (107)	130 (59)
AK125R	AK4125R	2	50 (11)	1200	400 (28)	⑦ 25,000 (5,500)	150	300 (149)	225 (107)	170 (77)	300 (136)	...
AL125R	AL4125R	2	75 (17)	1200	400 (28)	⑦ 25,000 (5,500)	150	300 (149)	225 (107)	173 (79)	303 (138)	...
K125R	K4125R	2	75 (17)	780	400 (28)	25,000 (5,500)	200	300 (149)	225 (107)	...	327 (148)	...
KK125R	KK4125R	2	100 (23)	780	400 (28)	25,000 (5,500)	200	300 (149)	225 (107)	...	334 (152)	550 (250)
L125R	L4125R	2	135 (31)	640	400 (28)	25,000 (5,500)	200	300 (149)	225 (107)	...	380 (173)	590 (268)
LQ125R	LQ4125R	④ 2½	135 (31)	640	400 (28)	25,000 (5,500)	200	300 (149)	225 (107)	...	415 (188)	625 (297)
LL125R	LL4125R	④ 3	140 (32)	520	400 (28)	2,500 (550)	200	300 (149)	225 (107)	...	445 (202)	655 (318)
LS125R	LS4125R	④ 3	200 (45)	640	400 (28)	75,000 (16,500)	150	300 (149)	225 (107)	...	490 (222)	700 (454)
Q125R	Q4125R	④ 4	300 (68)	520	400 (28)	7,500 (1,650)	150	300 (149)	225 (107)	1000 (499)
QS125R	QS4125R	④ 6	500 (114)	520	400 (28)	75,000 (16,500)	150	300 (149)	225 (107)	1100 (499)
M125R	M4125R	④ 4	420 (95)	420	400 (28)	25,000 (5,500)	150	300 (149)	225 (107)	1140 (518)

① Buna-N elastomer used in mechanical seal of Series 4125 pumps. Viton® Neoprene, and PTFE mechanical seals also available.

② For mechanical seal pumps on applications with viscosities above 15,000 SSU (3,300 cSt), provide details for recommendation.

③ For maximum recommended discharge pressures when handling other viscosities and/or at other speeds, see performance curves. If suction pressure exceeds 50 PSIG (3 BAR), consult factory.

Metric conversions are based on US measurements and rounded to the nearest whole number.

④ Ports are suitable for use with 125# ANSI cast iron or 150# ANSI steel companion flanges or flanged fittings. All others tapped for standard pipe.

⑤ Nominal rating based on handling thin liquids.

⑥ Standard seal can be used from -20°F. to +225°F. With special construction, temperatures from -60°F. to +650°F. can be handled with this series pumps.

⑦ “AK” and “AL” sizes not available in steel-fitted construction.

Viton® — Registered trademark of DuPont Performance Elastomers.

OUTSTANDING FEATURES

- Mounts NEMA standard motors, 1200 or 1800 RPM. (5 HP, 1800 RPM maximum with “A” reducer; 15 HP, 1800 RPM maximum with “B” reducer; and 50 HP, 1800 RPM maximum with “C” reducer.)
- Complete reducers within a size may be interchanged on a pump unit to obtain desired pump speeds and capacities. Thus the four gear ratios within the “A” size reducer may be interchanged within the size by selecting the proper pinion and gear of a common ratio. Similarly, all eight “B” reducers are interchangeable on each respective series of “B” reducer units. All seven “C” reducers are interchangeable on each respective series of “C” reducer units.
- Quiet operation. High hardness helical gears run in a bath of oil.
- Compact, narrow and low to fit in small space and low overhead.
- Pump, motor, or reducer can be removed without disturbing the other two components.
- Units with “A”, “B” and “C” reducers have standard flexible coupling with guard between power and reducer as well as between reducer and pump.
- Oil and weathertight for outdoor service.
- Ball bearings throughout.
- Reducers easily adjustable to different motor center heights.
- Self-supported. Not hung on pump or motor shafts. No radial load on pump or motor shafts.
- “A” reducers have ¾” dia., ⅜” key input and output shafts; “B” reducers have 1” dia., ¼” key input shaft and 1⅝” dia., ¼” key output shaft; “C” reducers have 1⅜” dia., ⅝” key input and output shafts.

VIKING® HEAVY DUTY PUMPS

SERIES 125 AND 4125

Section	141
Page	141.5
Issue	D

VIKING HELICAL GEAR REDUCTION UNITS (“R” DRIVE)

HELICAL REDUCER HORSEPOWER TABLE ② — “A” SIZE

HIGH SPEED SHAFT INPUT RPM ①	GEAR REDUCER RATIOS “A” SIZE				
	2.24:1	2.76:1	3.43:1	4.17:1	
1750	780	640	520	420	LOW SPEED SHAFT RPM
	6.1	4.9	3.8	3.1	MAXIMUM REDUCER HP
1450	640	520	420	350	LOW SPEED SHAFT RPM
	5.2	4.2	3.2	2.7	MAXIMUM REDUCER HP
1150	520	420	350	280	LOW SPEED SHAFT RPM
	4.3	3.4	2.6	2.2	MAXIMUM REDUCER HP
950	420	350	280	230	LOW SPEED SHAFT RPM
	3.6	2.9	2.2	1.8	MAXIMUM REDUCER HP

① For input speeds higher than 1750 RPM, consult the factory.

② Horsepower ratings based on 8-10 hours operation per day, electric motor drive. See Catalog Section 610 for specific reducer sizing information.

HELICAL REDUCER HORSEPOWER TABLE ② — “B” SIZE

HIGH SPEED SHAFT INPUT RPM	GEAR REDUCER RATIOS “B” SIZE								
	① 1.87:1	① 2.24:1	2.76:1	3.40:1	4.19:1	5.06:1	6.27:1	7.65:1	
1750	950	780	640	520	420	350	280	230	LOW SPEED SHAFT RPM
	19.0	17.0	15.0	13.0	11.0	9.5	7.6	6.4	MAXIMUM REDUCER HP
1450	780	640	520	420	350	280	230	190	LOW SPEED SHAFT RPM
	17.3	15.5	13.4	11.6	9.9	8.5	6.4	5.4	MAXIMUM REDUCER HP
1150	640	520	420	350	280	230	190	155	LOW SPEED SHAFT RPM
	16.5	14.0	11.6	10.1	8.5	7.3	5.3	4.4	MAXIMUM REDUCER HP
950	520	420	350	280	230	190	155	125	LOW SPEED SHAFT RPM
	15.5	12.8	10.1	9.0	7.6	6.0	4.3	3.7	MAXIMUM REDUCER HP

① For input speeds higher than 1750 RPM, consult the factory.

② Horsepower ratings based on 8-10 hours operation per day, electric motor drive. See Catalog Section 610 for specific reducer sizing information.

HELICAL REDUCER HORSEPOWER TABLE ② — “C” SIZE

HIGH SPEED SHAFT INPUT RPM	GEAR REDUCER RATIOS “C” SIZE							
	① 2.21:1	2.80:1	3.31:1	4.21:1	5.08:1	6.24:1	7.95:1	
1750	780	640	520	420	350	280	220	LOW SPEED SHAFT RPM
	49.8	43.5	39.0	32.4	26.6	19.7	18.0	MAXIMUM REDUCER HP
1450	640	520	420	350	280	230	180	LOW SPEED SHAFT RPM
	45.3	36.6	32.8	27.2	22.3	16.7	15.2	MAXIMUM REDUCER HP
1150	520	420	350	280	230	190	145	LOW SPEED SHAFT RPM
	40.1	30.0	26.8	22.2	18.2	13.8	12.6	MAXIMUM REDUCER HP
950	420	350	280	230	190	155	120	LOW SPEED SHAFT RPM
	29.1	24.7	22.1	18.3	15.0	11.4	10.4	MAXIMUM REDUCER HP

① For input speeds higher than 1750 RPM, consult the factory.

② Horsepower ratings based on 8-10 hours operation per day, electric motor drive. See Catalog Section 610 for specific reducer sizing information.

Section	141
Page	141.6
Issue	D

VIKING® HEAVY DUTY PUMPS

SERIES 125 AND 4125

GEAR REDUCER UNITS (“P” DRIVE) AND DIRECT DRIVE UNITS (“D” DRIVE)

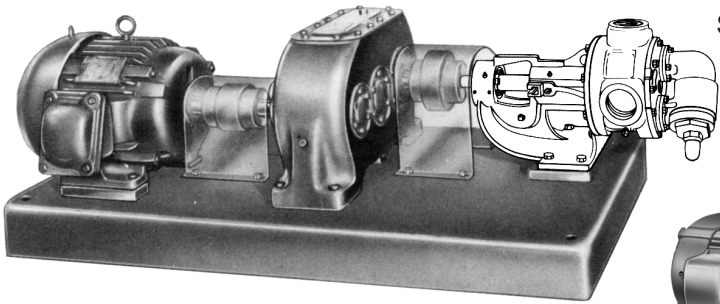

SERIES 125 and 4125 Pumps
with “P” Drive
“K” through “LS” Sizes

SERIES 125 and 4125 Pumps
with “P” Drive
“Q” through “M” Sizes
(shown without pressure relief valve)

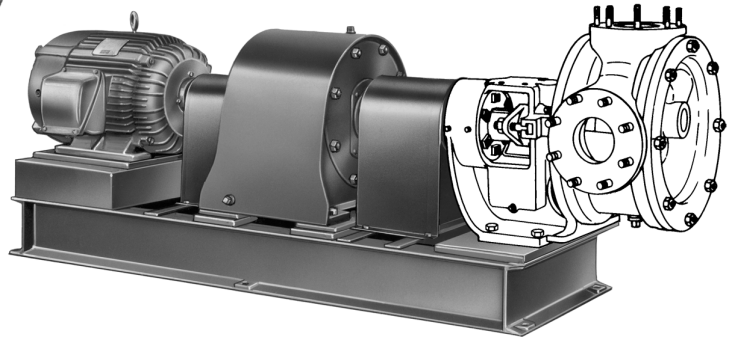

Heavy-duty Series 125 and 4125 packed and mechanical seal pumps in sizes from “K” through “M” are available in the “P” drive arrangement.

These heavy-duty units are mounted on formed steel bases (“K” through “LS” sizes) and structural or formed steel bases (“Q” through “M” sizes) as illustrated above.

All mount separate heavy-duty reducers with flexible couplings between pump, reducer, and motor. Coupling guards as illustrated are standard construction. Contact factory for specifications and motor horsepower range.

Dimensions for “P” Drive Units — Consult Factory.

Performance Data for “P” Drive Units — See Pages 142.27 through 141.42.

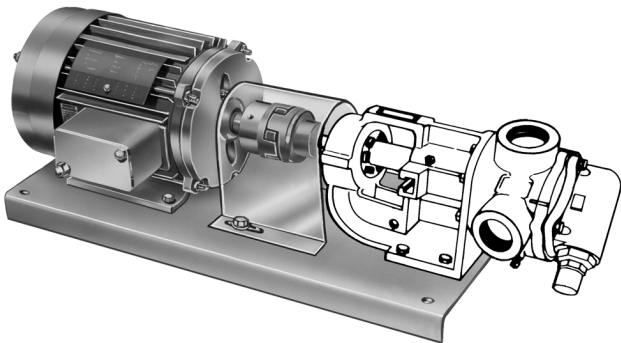

SERIES 125 and 4125 Pumps
with “D” Drive
“G,” “H” and “HL” Sizes

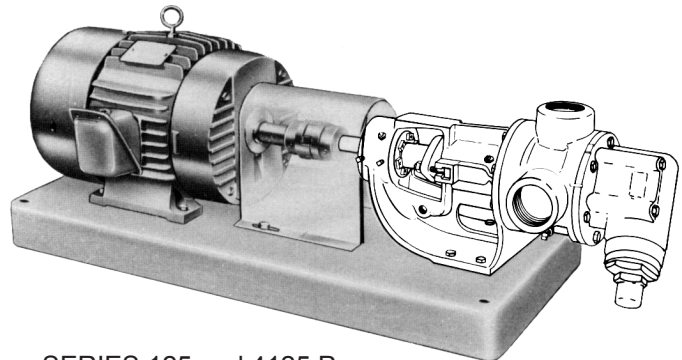

SERIES 125 and 4125 Pumps
with “D” Drive
“AK” and “AL” Sizes

The Direct Drive “D” mounting is specifically designed for compactness and quietness of operation. In this type assembly the pump is mounted on one end of a rectangular formed steel base and connected to a motor by means of a flexible coupling with guard. “G,” “H,” and “HL” sizes can be directly connected to 1800 RPM motors as well as gearhead motors. “AK” and “AL” size pumps are direct connected to 1200 RPM motors or gearhead motors providing high-capacity, compact pumping unit.

Dimensions for “D” Drive Units (“G” through “AL” sizes)— See Page 141.9.

Performance Data for “D” Drive Units—See Pages 141.15 through 141.42.

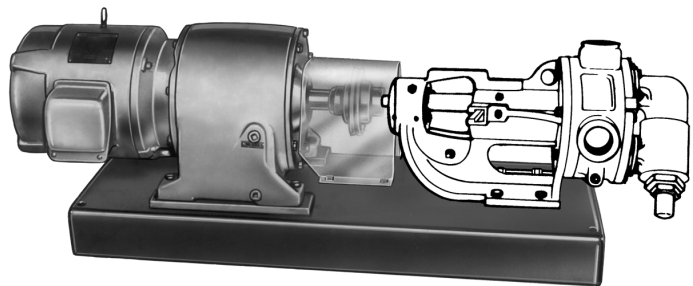

SERIES 125 and 4125 Pumps
with “D” Drive, Gearhead Motor
“K” through “M” Sizes

VIKING® HEAVY DUTY PUMPS

SERIES 125 AND 4125

Section	141
Page	141.7
Issue	E

V-BELT DRIVE UNITS (“V” DRIVE)

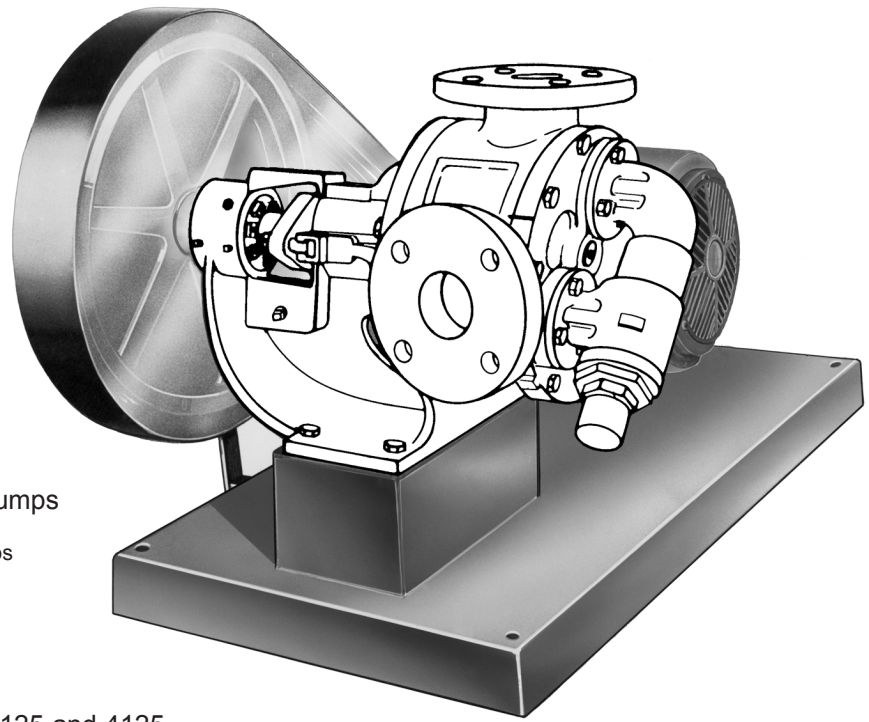

SERIES 125 and 4125 Pumps
with “V” Drive
“G” through “M” Size Pumps

V-belt driven line of heavy-duty Series 125 and 4125 pumps are all mounted on formed welded steel bases. Pumps mount on pads to accept totally enclosed V-belt drive. All units in this series feature standard pump shaft extension with totally guarded V-driven pulley mounted on end of heavy-duty pump shaft.

Dimensions for “V” Drive Units—See Page 141.12.
Performance Data for “V” Drive Units—See Pages 141.15 through 410.42.

SPECIFICATIONS — “V” DRIVE UNITS

Model Numbers		Port Size	⑤ Nominal Pump Rating		Maximum Hydrostatic Pressure	Steel-Fitted Construction Recommended Above This Viscosity	③ Maximum Recommended Discharge Pressure When Handling 100 SSU Liquid At Nominal Rated Speeds	⑥ Maximum Recommended Temperature For Cataloged Pump, °F. (°C.)		Approximate Shipping Weight With Valve (Less Power)
Packed	①② Mech. Seal	Inches	GPM (m³/hr)	RPM	PSIG (BAR)	SSU (cSt)	PSIG	Packed	Mech. Seal	Pounds (KG)
G125V	G4125V	1	8 (2)	1800	400 (28)	7,500 (1,650)	200	300 (149)	225 (107)	93 (42)
H125V	H4125V	1½	15 (3)	1800	400 (28)	25,000 (5,500)	200	300 (149)	225 (107)	109 (49)
HL125V	HL4125V	1½	30 (7)	1800	400 (28)	7,500 (1,650)	200	300 (149)	225 (107)	114 (52)
K125V	K4125V	2	75 (17)	780	400 (28)	25,000 (5,500)	200	300 (149)	225 (107)	255 (116)
KK125V	KK4125V	2	100 (23)	780	400 (28)	25,000 (5,500)	200	300 (149)	225 (107)	265 (120)
L125V	L4125V	2	135 (31)	640	400 (28)	25,000 (5,500)	200	300 (149)	225 (107)	305 (138)
LQ125V	LQ4125V	④ 2½	135 (31)	640	400 (28)	25,000 (5,500)	200	300 (149)	225 (107)	340 (154)
LL125V	LL4125V	④ 3	140 (32)	520	400 (28)	2,500 (550)	200	300 (149)	225 (107)	365 (166)
LS125V	LS4125V	④ 3	200 (45)	640	400 (28)	75,000 (16,500)	150	300 (149)	225 (107)	375 (170)
Q125V	Q4125V	④ 4	300 (68)	520	400 (28)	7,500 (1,650)	150	300 (149)	225 (107)	986 (448)
QS125V	QS4125V	④ 6	500 (114)	520	400 (28)	75,000 (16,500)	150	300 (149)	225 (107)	1,100 (499)
M125V	M4125V	④ 4	420 (95)	420	400 (28)	25,000 (5,500)	150	300 (149)	225 (107)	1,138 (517)

① Buna-N elastomer used in mechanical seal of Series 4125 pumps. Viton®, Neoprene, and PTFE mechanical seals also available.

② For mechanical seal pumps on applications with viscosities above 15,000 SSU (3,300 cSt), provide details for recommendation.

③ For maximum recommended discharge pressures when handling other viscosities and/or at other speeds, see performance curves. If suction pressure

exceeds 50 PSIG (3 BAR), consult factory.

④ Ports are suitable for use with 125# ANSI cast iron or 150# ANSI steel companion flanges or flanged fittings. All others tapped for standard pipe.

⑤ Nominal rating based on handling thin liquids.

⑥ Standard seal can be used from -20°F. to +225°F. With special construction, temperatures from -60°F. to +650°F. can be handled with this series pumps.

Section	141
Page	141.8
Issue	D

VIKING® HEAVY DUTY PUMPS

SERIES 125 AND 4125

DIMENSIONS

These dimensions are average and not for construction purposes. Certified prints on request.

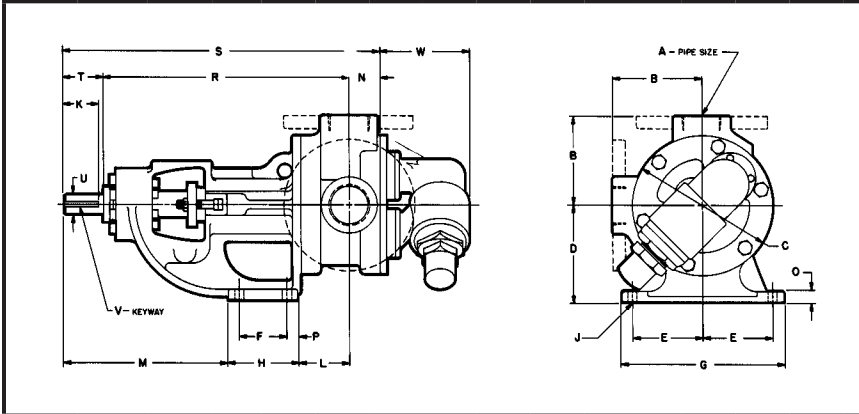

For specifications, see page 141.2.

DIMENSIONS— SERIES 125 AND 4125 UNMOUNTED PUMPS

① Ports are suitable for use with 125# ANSI cast iron or 150# ANSI steel companion flanges or flanged fittings. All others tapped for standard pipe.

MODEL NO.		A	B	C	D	E	F	G	H	J	K	L	M	N	O	P	R	S	T	U	V	W
PACKED	SEAL																					
G125	G4125	1	in 2.50 mm 64	3.50 89	2.75 70	1.62 41	1.31 33	4.00 102	2.44 62	.34 9	1.00 25	1.12 28	4.88 124	1.09 28	.31 8	.69 18	7.31 186	9.52 242	1.12 28	.50 13	.12 x .06 3.05 x 1.52	2.69 68
H125 HL125	H4125 HL4125	1½	in 3.00 mm 76	4.75 121	3.50 89	2.75 70	2.25 57	6.75 171	3.50 89	.47 12	1.50 38	3.38 86	5.19 132	1.19 30	.56 14	.62 16	10.44 265	13.25 337	1.62 41	.75 19.05	.19 x .09 4.76 x 2.38	2.88 73
AK125 AL125	AK4125 AL4125	2	in 4.50 mm 114	6.62 168	5.25 133	2.88 73	2.00 51	6.75 171	4.00 102	.41 10	2.25 57	2.81 71	8.88 226	2.00 51	.44 11	1.00 25	13.18 335	17.68 449	2.50 64	1.00 25.40	.25 x .12 6.35 x 3.18	4.80 122
K125 KK125	K4125 KK4125	2	in 5.12 mm 130	8.00 203	5.50 140	4.00 102	2.75 70	9.25 235	4.00 102	.53 13	2.00 51	3.00 76	9.38 238	1.75 44	.62 16	.62 16	14.12 359	18.12 460	2.25 57	1.12 28.58	.25 x .12 6.35 x 3.18	5.12 130
L125	L4125	2	in 6.50 mm 165	10.25 260	7.00 178	4.38 111	4.00 102	10.00 254	5.38 137	.53 13	2.00 51	3.38 86	9.12 232	1.75 44	.62 16	.62 16	15.62 397	19.62 498	2.25 57	1.12 28.58	.25 x .12 6.35 x 3.18	5.38 137
LQ125	LQ4125	① 2½	in 7.19 mm 183	10.25 260	7.00 178	4.38 111	4.00 102	10.00 254	5.38 137	.53 13	2.00 51	3.38 86	9.12 232	1.75 44	.62 16	.62 16	15.62 397	19.62 498	2.25 57	1.12 28.58	.25 x .12 6.35 x 3.18	5.38 137
LL125	LL4125	① 3	in 7.19 mm 183	10.25 260	7.00 178	4.38 111	4.00 102	10.00 254	5.38 137	.53 13	2.00 51	3.38 86	9.12 232	2.25 57	.62 16	.62 16	15.62 397	20.12 511	2.25 57	1.12 28.58	.25 x .12 6.35 x 3.18	5.38 137
LS125	LS4125	① 3	in 7.19 mm 183	10.25 260	7.00 178	4.38 111	4.00 102	10.00 254	5.38 137	.53 13	3.25 83	4.75 121	9.12 232	2.44 62	.62 16	.62 16	15.75 400	21.69 551	3.50 89	1.44 36.51	.38 x .19 9.53 x 4.76	5.19 132
Q125	Q4125	① 4	in 8.25 mm 210	14.00 356	8.75 222	4.12 105	4.00 102	10.00 254	6.00 152	.69 18	4.38 111	6.62 168	11.12 282	3.00 76	.75 19	1.00 25	19.25 489	26.75 679	4.50 114	1.94 49.21	50 x .25 12.70 x 6.35	8.19 208
M125	M4125	① 4	in 9.50 mm 241	17.25 438	10.00 254	5.00 127	6.00 152	12.00 305	8.50 216	.69 18	4.00 102	7.75 197	8.12 206	4.00 102	1.00 25	1.50 38	20.12 511	28.38 721	4.25 108	1.94 49.21	.50 x .25 12.70 x 6.35	8.50 216

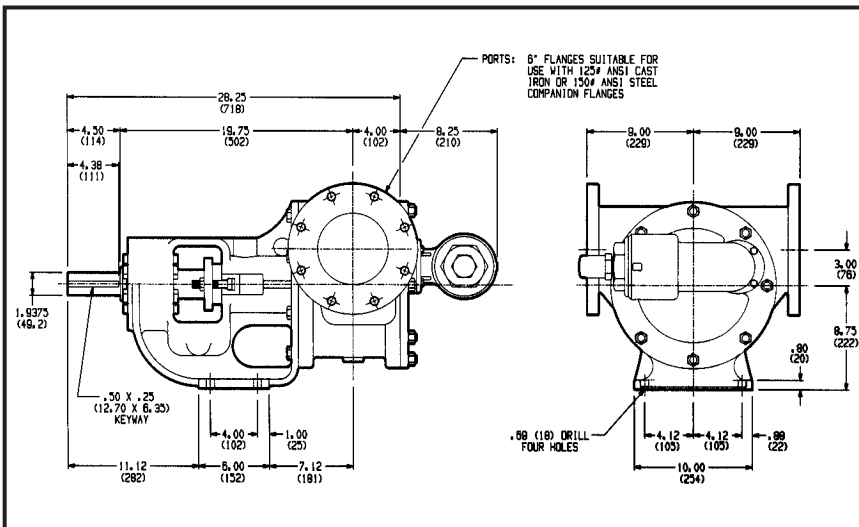

For specifications, see page 141.2.

DIMENSIONS— SERIES 125 AND 4125 UNMOUNTED PUMPS "QS" SIZE

NOTE: Dimensions shown in parentheses are millimeters; others are inches.

VIKING® HEAVY DUTY PUMPS

SERIES 125 AND 4125

Section	141
Page	141.9
Issue	D

DIMENSIONS

These dimensions are average and not for construction purposes. Certified prints on request.

For specifications, see pages 141.3 through 141.5.

DIMENSIONS— SERIES 125 AND 4125 ("R" DRIVE) "G" THROUGH "AL" SIZE PUMPS "A" SIZE REDUCER UNITS

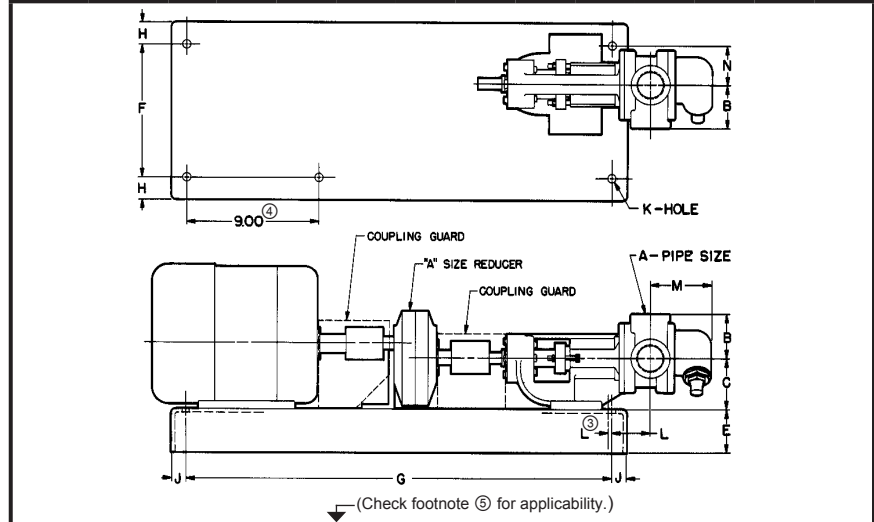

- ① Base suitable for motor frames 56 through 184-T on Models G, H, and HL through 215-T for Models AK and AL.
- ② For motor frames 213-T and 215-T, "G" dimension is increased to 34.00". All other dimensions remain the same. (Base has open ends.) Does not apply to Models AK and AL.
- ③ Location of pump port centerline on Models G125R and G4125R.
- ④ With motor frames 182-T and smaller, use the (four) corner base anchor holes. Motor frame 184-T covers up the lower left corner anchor hole, so the hole 9.00" to the right is used. Does not apply to Models AK and AL.
- ⑤ On Models G125R and G4125R, "E" dimension includes pump block. Base height is 2.94".

MODEL NUMBER		A	B	C	⑤ E	F	② G	H	J	K	L	M	N
PACKED	SEAL	1	2.50	2.75	3.69	9300	29.00	1.50	1.00	.56	③.12	3.75	1.81
			64	70	94	229	737	38	25	14	3	95	46
H125R AND HL125R	H4125R AND HL4125R	1½	3.00	3.50	2.94	9.00	29.00	1.50	1.00	.56	2.62	4.06	2.62
			76	89	75	229	737	38	25	14	67	103	67
AK125R AND AL125R	AK4125R AND AL4125R	2	4.50	5.25	4.00	16.00	39.00	1.38	1.38	.62	3.19	6.80	6.00
			114	133	102	406	991	35	35	16	81	173	152

For specifications, see pages 141.3 through 141.5.

DIMENSIONS— SERIES 125 AND 4125 ("R" DRIVE) "AK" THROUGH "LS" SIZE PUMPS "B" SIZE REDUCER UNITS

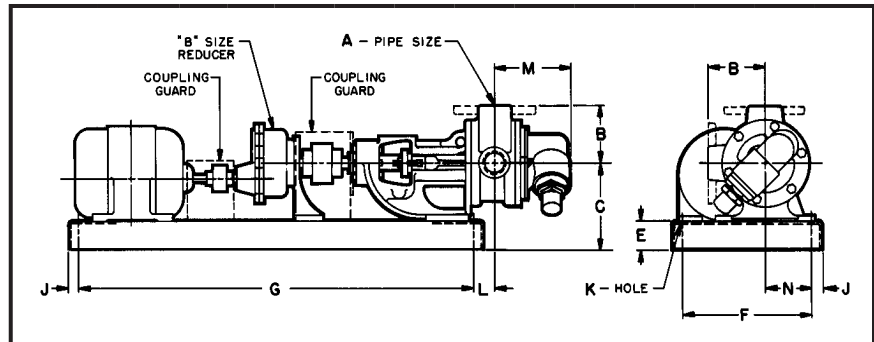

- ① Ports are suitable for use with 125# ANSI cast iron or 150# ANSI steel companion flanges or flanged fittings. All others tapped for standard pipe.
 - ① With motor frames 184-T and smaller, these units are assembled on a shorter base with the following dimension changes: (F = 16", G = 39", L = 3", N = 5½"). Motor rails 1½" high are required with 56, 143-T and 145-T frame motors.
- NOTE: Motor frame larger than 256-T requires larger base. Consult factory. Units available to accept 10HP, 1200 RPM maximum motor.
- NOTE: Motor rails 2" high are required on "L" through "LS" size units with 184-T or 4½" center height motors.

MODEL NUMBER		A	B	C	E	F	G	J	K	L	M	N	
PACKED	SEAL	2	in	4.50	9.50	4.00	14.25	48.00	1.38	.62	3.19	6.80	4.88
			mm	114	241	102	362	1219	35	16	81	173	124
② K125R AND KK125R	② K4125R AND KK4125R	2	in	5.12	9.50	4.00	14.25	48.00	1.38	.62	2.00	6.88	4.25
			mm	130	241	102	362	1219	35	16	51	175	108
L125R	L4125R	2	in	6.50	11.00	4.00	14.25	48.00	1.38	.62	2.38	7.12	4.62
			mm	165	279	102	362	1219	35	16	60	181	117
LQ125R	LQ4125R	① 2½	in	7.19	11.00	4.00	14.25	48.00	1.38	.62	2.38	7.12	4.62
			mm	183	279	102	362	1219	35	16	60	181	117
LL125R	LL4125R	① 3	in	7.19	11.00	4.00	14.25	48.00	1.38	.62	2.38	7.62	4.62
			mm	183	279	102	362	1219	35	16	60	194	117
LS125R	LS4125R	① 3	in	7.19	11.00	4.00	14.25	48.00	1.38	.62	2.38	7.62	4.62
			mm	183	279	102	362	1219	35	16	60	194	117

Section	141
Page	141.10
Issue	D

VIKING® HEAVY DUTY PUMPS

SERIES 125 AND 4125

DIMENSIONS

These dimensions are average and not for construction purposes. Certified prints on request.

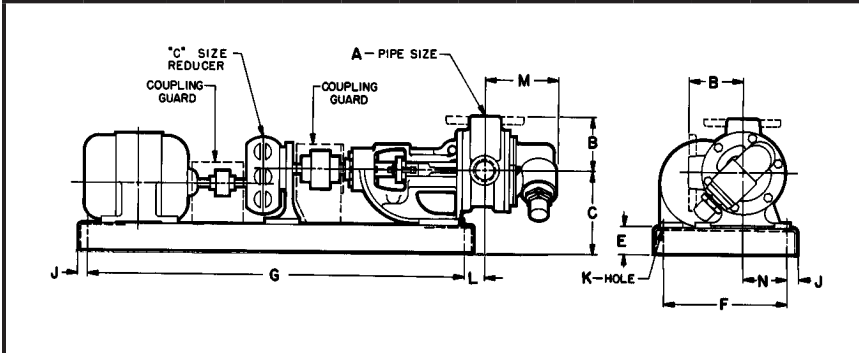

For specifications, see pages 141.3 through 141.5.

DIMENSIONS— SERIES 125 AND 4125 ("R" DRIVE) "KK" THROUGH "M" SIZE PUMPS (NOT FOR "QS" SIZE) "C" SIZE REDUCER UNITS

MODEL NUMBER		A	B	C	E	F	G	J	K	L	M	N
PACKED	SEAL											
KK125R	KK4125R	2	in 5.12	13.75	6.00	21.00	49.00	1.50	.69	3.00	6.88	6.06
			mm 130	349	152	533	1245	38	18	76	175	154
L125R	L4125R	2	in 6.50	13.75	6.00	19.75	59.50	1.50	.69	0	7.12	5.75
			mm 165	349	152	502	1511	38	18	0	181	146
LQ125R	LQ4125R	① 2½	in 7.19	13.75	6.00	19.75	59.50	1.50	.69	0	7.12	5.75
			mm 183	349	152	502	1511	38	18	0	181	146
LL125R	LL4125R	① 3	in 7.19	13.75	6.00	19.75	59.50	1.50	.69	0	7.62	5.75
			mm 183	349	152	502	1511	38	18	0	194	146
LS125R	LS4125R	① 3	in 7.19	13.75	6.00	19.75	59.50	1.50	.69	1.38	7.62	5.75
			mm 183	349	152	502	1511	38	18	35	194	146
Q125R	Q4125R	① 4	in 8.25	14.75	6.00	19.75	59.50	1.50	.69	5.88	11.19	5.75
			mm 210	375	152	502	1511	38	18	73	284	146
M125R	M4125R	① 4	in 9.50	16.00	6.00	19.75	59.50	1.50	.69	6.50	12.50	5.75
			mm 241	406	152	502	1511	38	18	89	318	146

① Ports are suitable for use with 125# ANSI cast iron or 150# ANSI steel companion flanges or flanged fittings. All others tapped for standard pipe.

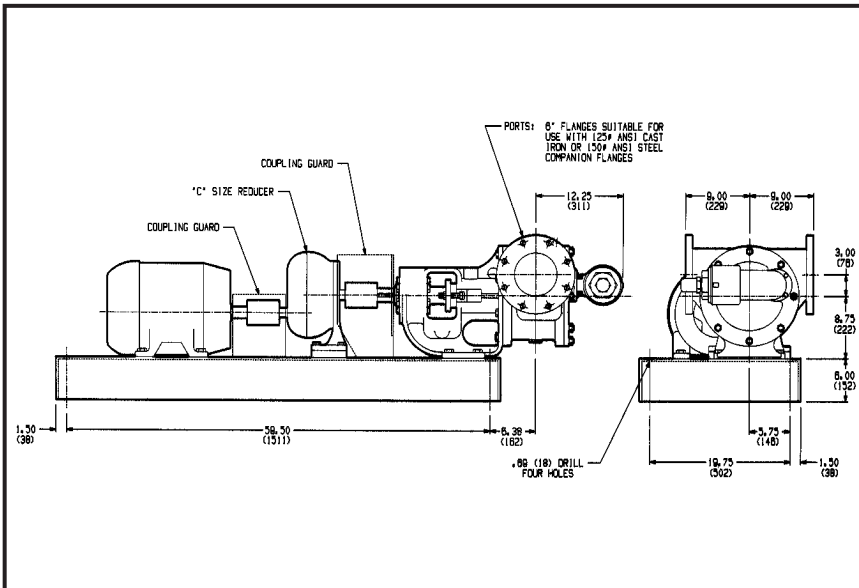

For specifications, see pages 141.3 through 141.5.

DIMENSIONS— SERIES 125 AND 4125 "QS" SIZE PUMPS "C" SIZE REDUCER UNITS

NOTE: Dimensions shown in parentheses are millimeters; others are inches.

VIKING® HEAVY DUTY PUMPS

SERIES 125 AND 4125

Section	141
Page	141.11
Issue	D

DIMENSIONS

These dimensions are average and not for construction purposes. Certified prints on request.

For description, see page 141.6.

DIMENSIONS — SERIES 125 AND 4125 ("D" DRIVE) "G" SIZE PUMPS DIRECT CONNECTED UNITS

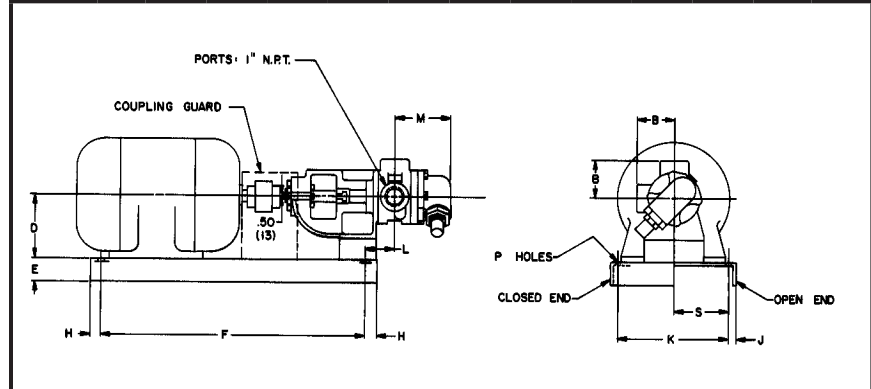

		B	D	FRAME	E	F	H	J	K	L	M	P	S
G125D OR G4125D	in	2.50	3.50	56	1.50	17.50	.75	.75	8.50	1.88	3.75	.53	4.25
	mm	64	89		38	445	19	19	216	48	95	13	108
	in	2.50	3.50	143T OR 145T	1.50	20.50	.75	.75	8.50	1.88	3.75	.50	4.25
	mm	64	89		38	521	19	19	216	48	95	13	108
	in	2.50	4.50	182T OR 184T	1.50	20.50	.75	.75	8.50	1.88	3.75	.50	4.25
	mm	64	114		38	521	19	19	216	48	95	13	108
in	2.50	5.25	213T OR 215T	2.94	25.00	1.00	1.50	9.00	1.88	3.75	.56	4.50	
mm	64	133		75	635	25	38	229	48	95	14	114	

For description, see page 141.6.

DIMENSIONS — SERIES 125 AND 4125 ("D" DRIVE) "H" THROUGH "AL" SIZE PUMPS DIRECT CONNECTED UNITS

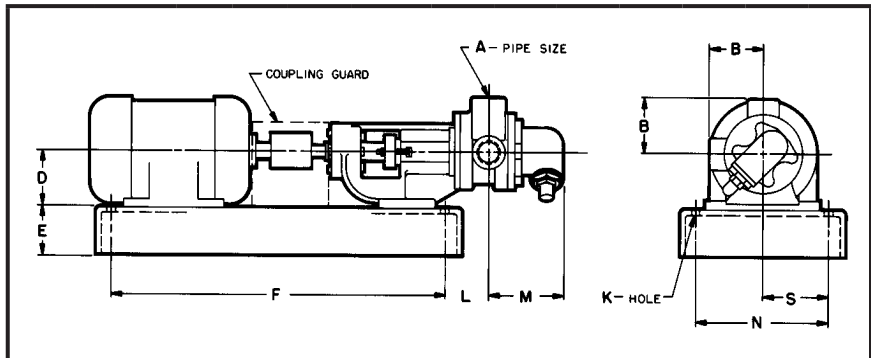

MODEL NUMBER		A	B	D	E	F	K	L	M	N	S	
H125D OR HL125D	H4125D OR HL4125D	1½	in	3.00	① 3.50	1.50	20.50	.50	1.75	4.06	8.50	4.25
			mm	76	89	38	521	13	44	103	216	108
		1½	in	3.00	② 4.50	2.94	25.00	.56	.56	4.06	9.00	4.50
			mm	76	114	75	635	14	14	103	229	114
AK125D OR AL125D	AK4125D OR AL4125D	2	in	4.50	④ 5.25	2.94	26.00	.56	3.56	6.80	9.00	4.50
			mm	114	133	75	660	14	90	173	229	114
		2	in	4.50	⑤ 5.25	2.94	29.00	.56	3.56	6.80	9.00	4.50
			mm	114	133	75	737	14	90	173	229	114
		2	in	4.50	⑥ 6.25	4.00	39.00	.62	3.19	6.80	16.00	8.00
			mm	114	159	102	991	16	81	173	406	203
2	in	4.50	⑦ 7.00	4.00	39.00	.62	3.19	6.80	16.00	8.00		
	mm	114	178	102	991	16	81	173	406	203		

- ① For motor frames 56, 143-T, and 145-T. (Base has open ends.)
- ② For motor frames 182, 182-T, 184, and 184-T. (Base has closed ends.)
- ③ For motor frames 213 through 215-T. (Base has closed ends.)
- ④ For motor frames 182 through 184-T. Dimension includes block under motor. (Base has open ends.)
- ⑤ For motor frames 213 through 215-T. (Base has open ends.)
- ⑥ For motor frames 254 through 256-T. (Base has closed ends.)
- ⑦ For motor frames 284 through 286-T. (Base has closed ends.)

Section	141
Page	141.12
Issue	D

VIKING® HEAVY DUTY PUMPS

SERIES 125 AND 4125

DIMENSIONS

These dimensions are average and not for construction purposes. Certified prints on request.

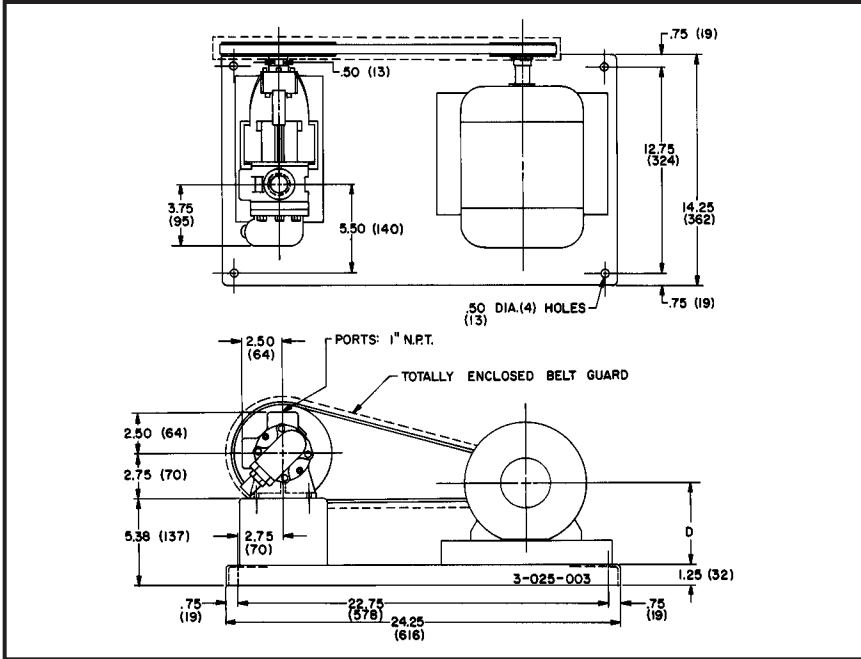

For specifications, see page 141.7.

DIMENSIONS — SERIES 125 AND 4125 ("V" DRIVE) "G" SIZE PUMPS V-BELT DRIVE UNITS

NOTE: For motor frames 56 and 143-T. Maximum frame size is 143-T. "D" dimension for motor frame 56 is 3.50" (89 mm) less rail; for motor frame 143-T, 5.00" (127 mm) with rail.

NOTE: Dimensions shown in parentheses are millimeters; others are inches.

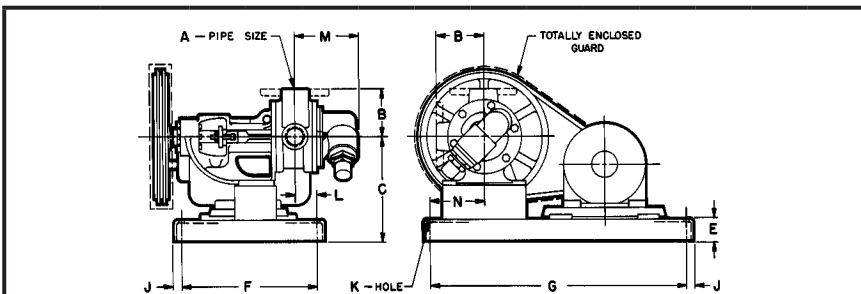

For specifications, see page 141.7.

DIMENSIONS — SERIES 125 AND 4125 ("V" DRIVE) "H" THROUGH "M" SIZE ④ PUMPS V-BELT DRIVE UNITS

MODEL NUMBER		A	B	C	E	F	G	J	K	L	M	N	
H125V ② AND HL125V	H4125V AND HL4125V	1½	in	3.00	9.25	1.75	14.75	23.75	.75	.50	4.88	4.06	4.25
			mm	76	235	44	375	603	19	13	124	103	108
K125D ③ AND KK125D	K4125V AND KK4125V	2	in	5.12	13.81	3.25	17.00	28.75	1.00	.50	2.50	6.88	5.25
			mm	130	351	83	432	730	25	13	64	175	133
③ L125V	L4125V	2	in	650	15.31	3.25	17.00	28.75	1.00	.50	2.25	7.12	5.25
			mm	165	389	83	432	730	25	13	57	181	133
③ LQ125V	LQ4125V	① 2½	in	7.19	15.31	3.25	17.00	28.75	1.00	.50	2.25	7.12	5.25
			mm	183	389	83	432	730	25	13	57	181	133
③ LL125V	LL4125V	① 3	in	7.19	15.31	3.25	17.00	28.75	1.00	.50	2.25	7.62	5.25
			mm	183	389	83	432	730	25	13	57	194	133
③ LS125V	LS4125V	① 3	in	7.19	15.31	3.25	17.00	28.75	1.00	.50	1.06	7.62	5.25
			mm	183	389	83	432	730	25	13	27	194	133
Q125V	Q4125V	① 4	in	8.25	21.25	6.00	21.00	49.00	1.50	.81	2.75	11.19	8.50
			mm	210	540	152	533	1245	38	21	70	284	216
M125V	M4125V	① 4	in	9.50	22.50	6.00	21.00	49.00	1.50	.81	2.12	12.50	8.50
			mm	241	572	152	533	1245	38	21	54	318	216

① Ports are suitable for use with 125# ANSI cast iron or 150# ANSI steel companion flanges or flanged fittings. All others tapped for standard pipe.

② Base dimensions correct for all motors.

③ Base dimensions correct through frame 215-T motors and 19" OD sheaves. Larger motors and/or 25" OD sheaves require larger base.

④ "QS" size pump drawing available on request.