

TPMC117 6 Channel SSI, Incremental Encoder, Counter

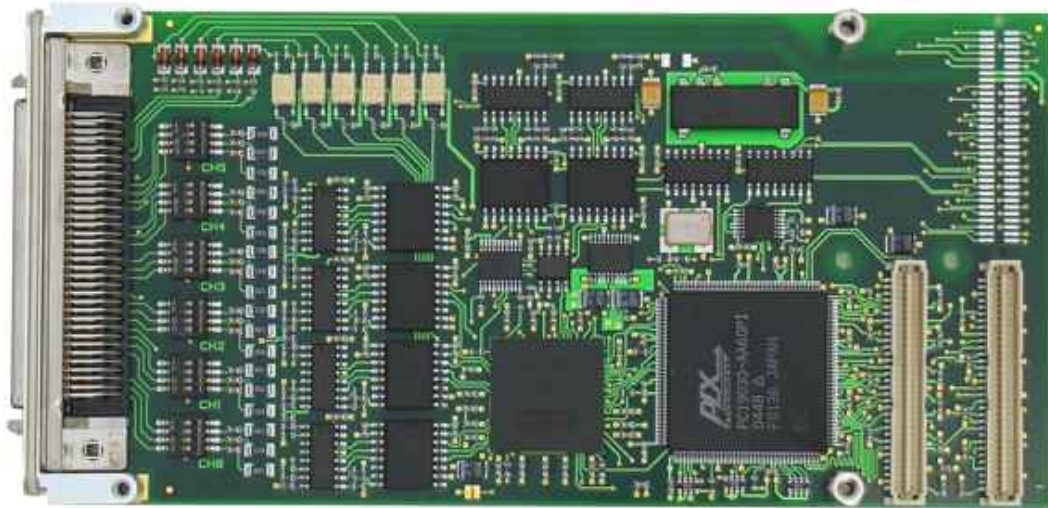

Application Information

The TPMC117 is a standard single-width 32 bit PMC module and offers six independent channels. Each of these channels can operate as a standard SSI interface controller, in a SSI 'Listen only' Mode, as an incremental encoder or general purpose counter.

The standard SSI interface controller outputs a clock burst to the absolute encoder and receives the returned positional data. The SSI interface controller operates with a programmable clock rate from 1 μ s to 15 μ s and programmable data word length from 1 bit to 32 bit.

In 'Listen only' Mode the channel listens to an existing SSI interface to observe its data transfer. It takes both the SSI clock and data as inputs. In 'Listen only' Mode the channel also has a programmable data word length from 1 bit to 32 bit; the SSI clock rate of the observed SSI interface can be in the range of 1 μ s to 15 μ s.

In both modes the data word can be encoded in Binary- or in Gray code and with odd, even or no parity.

The 32 bit incremental encoder counter is a preloadable up- and down counter. The counter is programmable for single, double and quadruple analysis of the encoder signals. In conjunction with the isolated 24V digital inputs it provides the possibility of automatic preload of the counter whenever the motion system passes a reference position.

The 32 bit general purpose preloadable up- and down counter can be fed with an internal clock or with external signals.

Both counter modes offer a 32 bit preload register, a 32 bit compare register and various count modes.

A 'Multiple Channel Read' function latches the actual values of all enabled channels whose values can then be read without interfering with normal function.

In addition the TPMC117 provides a 16 bit down-counter with preload register which allows timing intervals of up to 65ms. It can be used as reference timer for closed loop applications or as trigger for the Multiple Channel Read function.

All data inputs are isolated. The level of the input signals can be RS422 or TTL. The input signals pass a digital filter for noise suppression before they are further used.

The level of the SSI clock output signals is RS422.

Each of the six motion control channels of the TPMC117 offers one isolated 24V digital input. The input circuit ensures a defined switching point and polarization protection against confusing the pole. The input has an electronic debounce circuit. All six 24V digital inputs can generate an interrupt, triggered on rising or falling edge. Depending on the selected mode the input can be used as general purpose input or reference input.

All TPMC117-10R signals are accessible through a HD68 SCSI-3 type front I/O connector. The TPMC117-20R offers P14 back I/O and a dummy front panel.

The TPMC117 can operate with 3.3V and 5.0V PCI I/O signaling voltage.

Software Support (TDRV005-SW-xx) for different operating systems is available.

Technical Information

- Standard single-width 32 bit PMC module conforming to IEEE P1386.1
 - Target Chip: PCI9030 (PLX Technology)
 - PCI 2.2 compliant interface
 - 5V and 3.3V PCI I/O signaling voltage
- Board size: 149 mm x 74 mm
- HD68 SCSI-3 type I/O connector mounted in front panel
- 6 Channels, independently configurable as standard SSI interface controller, SSI 'Listen only' Mode, incremental encoder or general purpose counter
- Standard SSI Interface
 - SSI data word length programmable from 1 bit to 32 bit
 - Data word encoding: Binary- or Gray-Code
 - Parity: Odd, even or without
 - SSI clock rate: 1 μ s – 15 μ s
- SSI 'Listen only' Mode
 - SSI data word length programmable from 1 bit to 32 bit
 - Data word encoding: Binary- or Gray-Code
 - Parity: Odd, even or without
 - SSI clock rate: 1 μ s – 15 μ s
- 32 bit incremental encoder counter
 - 32 bit preload register
 - 32 bit compare register
 - 1x, 2x or 4x resolution multiplier
 - Reference preload function
 - Various count- and control modes
- 32 bit general purpose counter
 - 32 bit preload register
 - 32 bit compare register
 - Various count and control modes
- Multiple channel read
- 16 bit down-counter with preload
- Inputs are isolated and TTL/RS422 compatible
- 6 isolated 24 V digital inputs: reference input or general purpose input depending on mode
- Operating temperature -40°C to +85°C

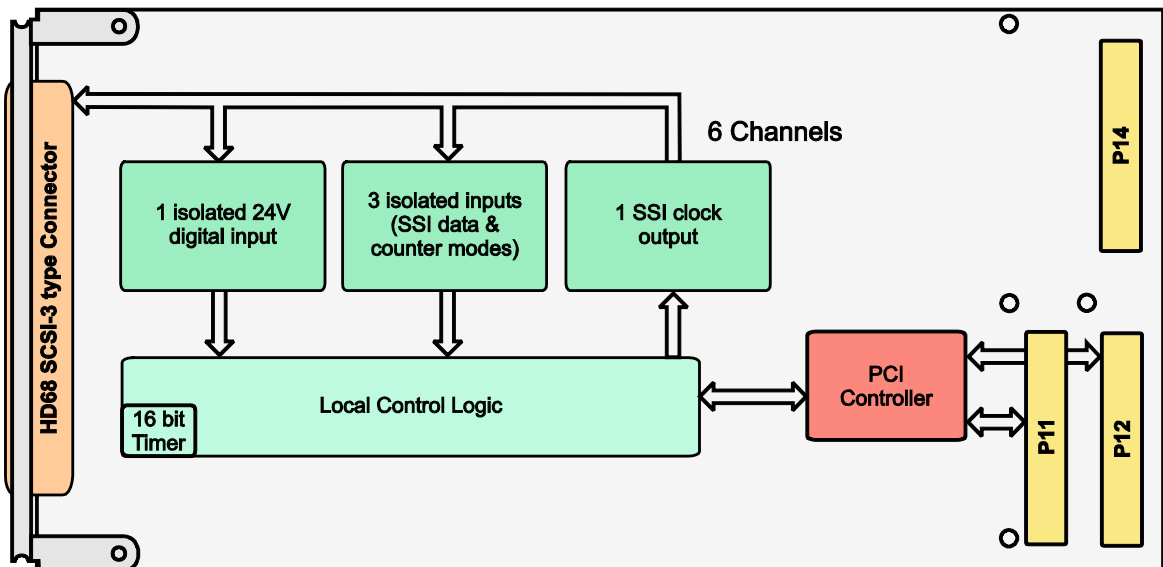

Order Information

RoHS Compliant

TPMC117-10R 6 Channel SSI, Incremental Encoder, Counter Interface, RS422 or TTL I/O, Timer, HD68

TPMC117-20R 6 Channel SSI, Incremental Encoder, Counter Interface, RS422 or TTL I/O, Timer, P14 I/O, no front panel

For the availability of non-RoHS compliant (lead solder) products please contact TEWS.

Documentation

TPMC117-DOC User Manual

Software

TDRV005-SW-25 Integrity Software Support

TDRV005-SW-42 VxWorks Software Support (Legacy and VxBus-Enabled Software Support)

TDRV005-SW-65 Windows Software Support

TDRV005-SW-82 Linux Software Support

TDRV005-SW-95 QNX Software Support

For other operating systems please contact TEWS.

Related Products

TA304 Cable Kit for Modules with HD68 Connector